



ReicoTM
KITCHEN & BATH

BATHROOM PLANNING GUIDE

HOW TO PLAN YOUR DREAM BATHROOM,
STEP-BY-STEP





Let's get
STARTED

ReicoTM
KITCHEN & BATH

The amount of time for any bathroom project will vary by the scope of the project. A straight tear and replace with little to no design changes that uses in stock cabinets and reuses the tub and/or shower can typically be done faster based on how quickly decisions are made and what schedules are.

A full bathroom remodel requires more time, effort and teamwork in every facet. Careful consideration needs to be given to multiple product and design decisions, which involves time and effort making both decisions and changes to layout and design.

It is important to understand the process. If something is not clear, ask. Remodeling is a roller coaster of emotions. In every scenario, patience wins. Let our Reico Kitchen & Bath designers expertly guide you every step of the way. It is what we do and what we've done since 1952.

Now it is time to learn about your bathroom project. Let's get started!

CLIENT INFORMATION

Name _____ Date _____

Address _____

Email _____ Phone _____

BATHROOM TYPE:

Primary Hall Powder Other

PROJECT GOALS

PLANNING details



CABINETRY DETAILS

Design Style:

- Traditional Contemporary Modern
 Transitional Shaker Rustic

- Wood: Cherry Maple Hickory
 Oak Other _____

- Finish: Light Medium White
 Painted Dark Stain

- Door Profile: Raised Shaker Recessed Slab

Cabinet Construction Options

- Framed Frameless Plywood Sides Wood Dovetail Drawers
 Soft Close Doors and Drawers Full Extension Undermount Drawer Guides

BATHROOM FIXTURE DETAILS

Existing Bathroom Fixtures to be kept (select none/all that apply):

- Toilet Shower Mirror Grab Bar
 Bidet Shower Door Towel Bar Robe Hook
 Bathtub Medicine Cabinet Towel Ring Toilet Tissue Holder

New Bathroom Fixtures (select none/all that apply):

- Toilet Shower Mirror Grab Bar
 Bidet Shower Door Towel Bar Robe Hook
 Bathtub Medicine Cabinet Towel Ring Toilet Tissue Holder

A word about wood and painted finish characteristics

Wood naturally offers variations in color, grains, pattern and texture, creating a uniqueness that adds to its appeal. These natural characteristics can not be hidden in finishing and are not to be misinterpreted as defects.

Painted finishes also feature unique characteristics derived from the wood underneath. Imperfections and natural characteristics of wood will stand out even more on a smooth painted finish. These are to be expected and not considered a defect in the workmanship or finish.

PLANNING details



Reico
KITCHEN & BATH

COUNTERTOP DETAILS

Material (select all that apply):

- Granite
- Solid Surface
- Quartz
- Cultured Marble
- Laminate
- Other _____

Sink Type (select all that apply):

- Single Bowl
- Oval
- Double Bowl
- Recessed Oval
- Undermount
- Vessel
- Drop-In

Faucet (select all that apply):

- Single Handle
- Two-Handle
- Single Hole
- Centerset
- Wall Mount
- 4" Drilling Standard
- 8" Drilling Wideset

TILE OPTIONS

Location (select all that apply):

- Main Floor
- Vanity Top Backsplash
- Shower Wall
- Shower Wall Inlay
- Shower Floor
- Shower Niche
- Bench
- Floor Heat
- Other

Size/Shape, Color and Pattern details:

TILE IN STYLE

From (hopefully) dry bathroom floors to wet shower floors, to countertop backsplashes and countless styles, colors and options for shower walls, inlays and niches, tile choices impact the look and feel of every bathroom.

Be sure to discuss:

Size: Large tile for the floor can make a space feel bigger but may not be what you want in the shower.

Colors & Focal Point: With multiple uses of tile, make sure you create a palette of colors and styles that complement each other. One focal point is all you need to make a statement.

Maintenance: No one loves cleaning the bathroom. Porcelain or Ceramic options typically require less maintenance. Natural stones are porous, require more effort to maintain, and must be sealed as well.

PLANNING

details



ADDITIONAL PROJECT INFORMATION

General Lighting: Keep Remove Update Add New Not Applicable

Task Lighting: Keep Remove Update Add New Not Applicable

Plumbing: Keep Remove Update Add New Not Applicable

Electrical: Keep Remove Update Add New Not Applicable

Flooring: Keep Remove Update Add New Not Applicable

Interior Walls: Keep Remove Update Add New Not Applicable

PROJECT BUDGET

SPECIAL REQUIREMENTS/ADDITIONAL PROJECT NOTES

how to measure for your **NEW BATHROOM**

- All you need is a tape measure, pencil and piece of paper.
- Starting in a corner, select a wall to measure.
- Note the total length of the wall plus every item on that wall and distances between.
- Repeat for all walls until everything is marked on your sketch.
- Note heights for door openings, windows, floor to ceiling and floor to soffit (if applicable).
- For windows, measure outside of casing to outside of casing.
- For doors, mark direction of door swing.
- Mark locations of sink, shower, tub and toilet.
- Mark locations of outlets and light switches if possible.

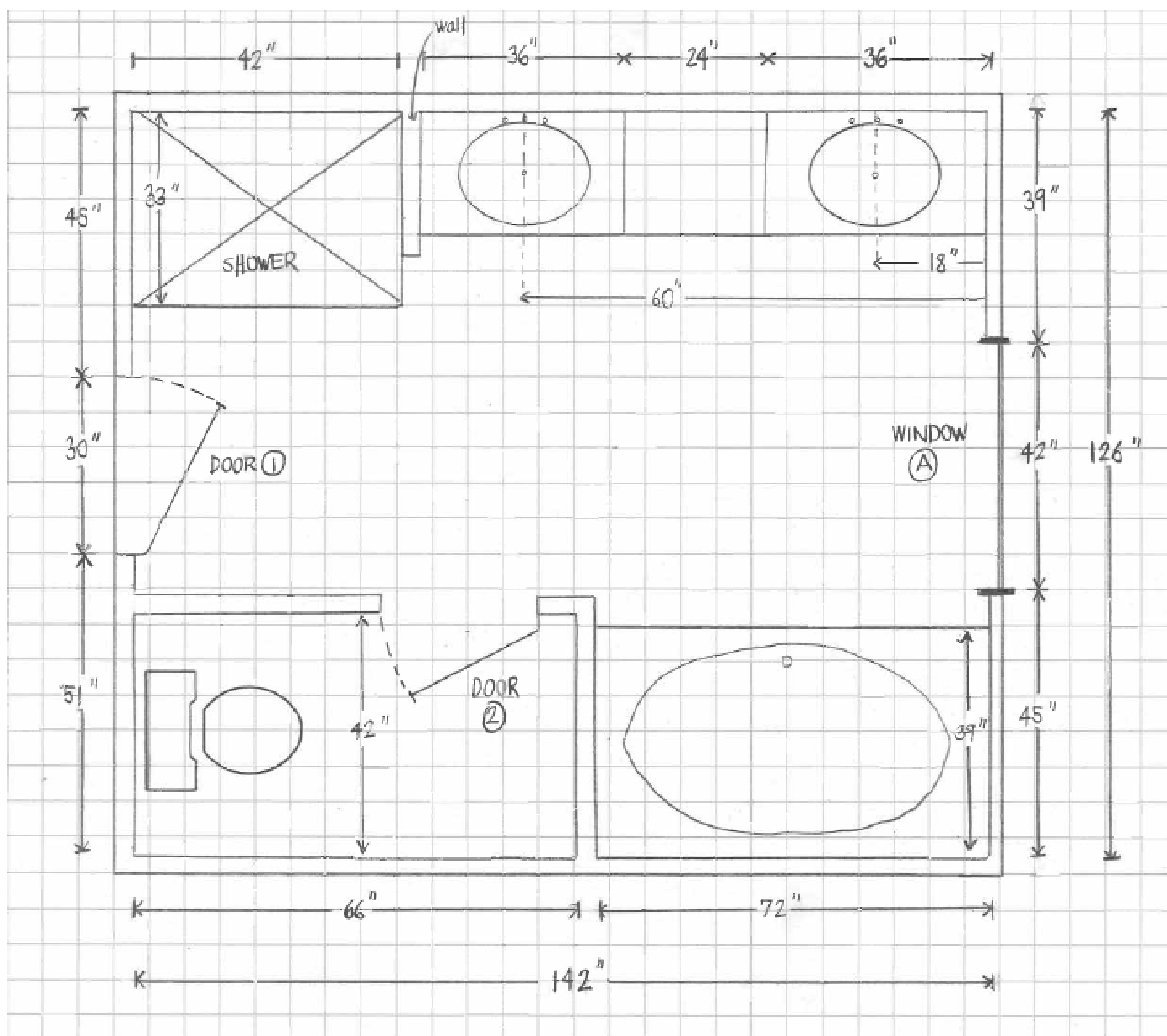

BATHROOM

floor plan

